

## Product Specification

### 10km 100GBASE-LR4 QSFP28 Optical Transceiver Module

### Finisar® Transceiver

### FTLC1156RDPL

#### PRODUCT FEATURES

- Hot-pluggable QSFP28 form factor
- Supports 103.1Gb/s aggregate bit rate
- Power dissipation < 3.5W
- RoHS-6 compliant
- Commercial case temperature range of 0°C to 70°C
- Adaptive CTLE
- Single 3.3V power supply
- Maximum link length of 10km on Single Mode Fiber (SMF)
- 4x25Gb/s DFB-based LAN-WDM transmitter
- 4x25G retimed electrical interface
- Duplex LC receptacles
- I2C management interface



#### APPLICATIONS

- 100GBASE-LR4 100G Ethernet

Finisar's FTLC1156RDPL QSFP28 transceiver modules are designed for use in 100 Gigabit Ethernet links on up to 10km of single mode fiber. They are compliant with the QSFP28 MSA<sup>1</sup>, IEEE 802.3ba 100GBASE-LR4<sup>2</sup> and IEEE 802.3bm CAUI-4<sup>3</sup>. Digital diagnostic functions are available via the I2C interface, as specified by the QSFP28 MSA and II-VI Application Notes AN-2152<sup>4</sup> and AN-2153<sup>5</sup>. The optical transceiver is RoHS compliant as described in Application Notes AN-2038<sup>6,7</sup>.

#### PRODUCT SELECTION

### FTLC1156RDPL

- 6: Gen 3
- R: 100GE-LR4 maximum bit rate (103.1 Gb/s)
- D: 4x25G LAN-WDM optical architecture
- P: Pull-tab release
- L: LC straight receptacle

## I. Pin Descriptions

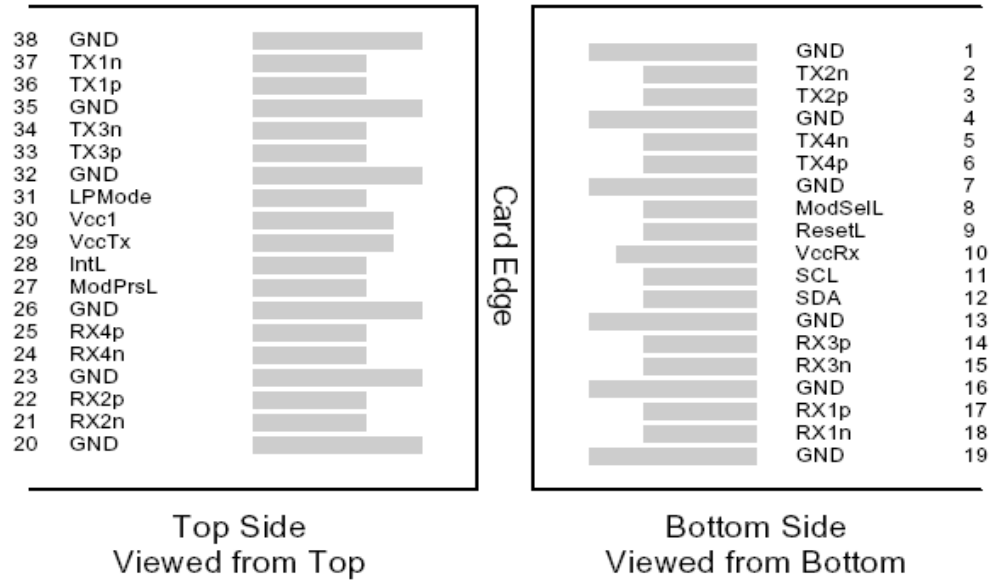

Figure 1 – QSFP28-compliant 38-pin connector (per SFF-8679)

Pin	Symbol	Name/Description	Notes
1	GND	Ground	1
2	Tx2n	Transmitter Inverted Data Input	
3	Tx2p	Transmitter Non-Inverted Data Input	
4	GND	Ground	1
5	Tx4n	Transmitter Inverted Data Input	
6	Tx4p	Transmitter Non-Inverted Data Input	
7	GND	Ground	1
8	ModSelL	Module Select	
9	ResetL	Module Reset	
10	Vcc Rx	+3.3 V Power supply receiver	
11	SCL	2-wire serial interface clock	
12	SDA	2-wire serial interface data	
13	GND	Ground	1
14	Rx3p	Receiver Non-Inverted Data Output	
15	Rx3n	Receiver Inverted Data Output	
16	GND	Ground	1
17	Rx1p	Receiver Non-Inverted Data Output	
18	Rx1n	Receiver Inverted Data Output	
19	GND	Ground	1
20	GND	Ground	1
21	Rx2n	Receiver Inverted Data Output	
22	Rx2p	Receiver Non-Inverted Data Output	
23	GND	Ground	1
24	Rx4n	Receiver Inverted Data Output	
25	Rx4p	Receiver Non-Inverted Data Output	
26	GND	Ground	1
27	ModPrsL	Module Present	
28	IntL	Interrupt	2

29	Vcc Tx	+3.3 V Power supply transmitter	
30	Vcc1	+3.3 V Power Supply	
31	LPMODE	Low Power Mode	2
32	GND	Ground	1
33	Tx3p	Transmitter Non-Inverted Data Input	
34	Tx3n	Transmitter Inverted Data Input	
35	GND	Ground	1
36	Tx1p	Transmitter Non-Inverted Data Input	
37	Tx1n	Transmitter Inverted Data Input	
38	GND	Ground	1

#### Notes

1. Circuit ground is internally isolated from chassis ground.
2. The IntL pin (“Interrupt Low”, pin 28) can be configured to act as an Rx\_LOS output; The LPMODE pin (“Low Power Mode”, pin 31) can be configured to act as an input for Tx\_Disable; These changes require customization. See Finisar Application Note AN-2174<sup>8</sup> for more details.

## II. Absolute Maximum Ratings

Module performance is not guaranteed beyond the operating range (see Section VI). Exceeding the limits below may damage the transceiver module permanently.

Parameter	Symbol	Min	Typ	Max	Unit	Ref.
Maximum Supply Voltage	Vcc	-0.5		3.6	V	
Storage Temperature	T <sub>S</sub>	-40		+85	°C	
Case Operating Temperature	T <sub>OP</sub>	0		+70	°C	
Relative Humidity	RH	15		85	%	1
Receiver Damage Threshold	P <sub>Rdmg</sub>	5.5			dBm	

#### Notes:

1. Non-condensing.

## III. Electrical Characteristics (EOL, T<sub>OP</sub> = 0 to +70 °C, V<sub>CC</sub> = 3.135 to 3.465 Volts)

Parameter	Symbol	Min	Typ	Max	Unit	Ref.
Supply Voltage	Vcc	3.135		3.465	V	
Supply Current	Icc			1.12	A	
Module total power	P			3.5	W	1
<b>Transmitter</b>						
Signaling rate per lane		25.78125 ± 100 ppm			GBd	
Differential data input swing per lane	V <sub>in,pp</sub>			900	mV	
Differential input return loss (min)	RL <sub>d</sub> (f)	9.5 – 0.37f, 0.01 ≤ f < 8 4.75 – 7.4log <sub>10</sub> (f/14), 8 ≤ f < 19			dB	
Differential to common mode input return loss (min)	RL <sub>dc</sub> (f)	22-20(f/25.78), 0.01 ≤ f < 12.89 15-6(f/25.78), 12.89 ≤ f < 19			dB	
Differential termination mismatch				10	%	
<b>Stressed input parameters</b>						
Eye width			0.46		UI	
Applied pk-pk sinusoidal jitter		Per IEEE 802.3bm Table 88-13				
Eye height			95		mV	
DC common mode voltage		-350		2850	mV	
<b>Receiver</b>						
Signaling rate per lane		25.78125 ± 100 ppm			GBd	
Differential data output swing	V <sub>out,pp</sub>	100		400	mVpp	2

		300		600		
		400		800		
		600		1200		
Eye width		0.57			UI	
Vertical eye closure				5.5	dB	
Differential output return loss (min)	RLd(f)	9.5 – 0.37f, 0.01 ≤ f < 8 4.75 – 7.41log <sub>10</sub> (f/14), 8 ≤ f < 19			dB	
Common to differential mode conversion return loss (min)	RLdc(f)	22-20(f/25.78), 0.01 ≤ f < 12.89 15-6(f/25.78), 12.89 ≤ f < 19			dB	
Differential termination mismatch				10	%	
Transition time, 20% to 80%	t <sub>r</sub> t <sub>f</sub>	12			ps	

**Notes:**

- Maximum total power value is specified across the full temperature and voltage range.
- Output voltage is settable in 4 discrete ranges via I2C. Default range is 400 – 800 mV.

**IV. Optical Characteristics (EOL, T<sub>OP</sub> = 0 to +70 °C, V<sub>CC</sub> = 3.135 to 3.465 Volts)**

Parameter	Symbol	Min	Typ	Max	Unit	Ref.
<b>Transmitter</b>						
Signaling Speed per Lane		25.78125 ± 100 ppm			Gb/s	1
Lane center wavelengths (range)		1294.53 – 1296.59 1299.02 – 1301.09 1303.54 – 1305.63 1308.09 – 1310.19			nm	
Total Average Launch Power	P <sub>OUT</sub>			10.5	dBm	
Transmit OMA per Lane	TxOMA	-1.3		4.5	dBm	
Average Launch Power per Lane	TXP <sub>x</sub>	-4.3		4.5	dBm	2,7
Optical Extinction Ratio	ER	4			dB	
Sidemode Suppression ratio	SSR <sub>min</sub>	30			dB	
Average launch power of OFF transmitter, per lane				-30	dBm	
Relative Intensity Noise	RIN			-130	dB/Hz	
Optical Return Loss Tolerance				20	dB	
Transmitter Reflectance				-12	dB	
Transmitter eye mask definition {X1, X2, X3, Y1, Y2, Y3}		{0.25, 0.4, 0.45, 0.25, 0.28, 0.4}				3
<b>Receiver</b>						
Signaling Speed per Lane		25.78125 ± 100 ppm			GBd	4
Lane center wavelengths (range)		1294.53 – 1296.59 1299.02 – 1301.09 1303.54 – 1305.63 1308.09 – 1310.19			nm	
Receive Power (OMA) per Lane	RxOMA			4.5	dBm	
Average Receive Power per Lane	RXP <sub>x</sub>	-10.6		4.5	dBm	5,7
Receiver Sensitivity (OMA) per Lane	Rxsens			-8.6	dBm	
Return Loss	RL	-26			dB	
Stressed Receiver Sensitivity (OMA) per Lane	SRS			-6.8	dBm	6
Receive electrical 3 dB upper cutoff frequency, per lane				31	GHz	
LOS De-Assert	LOS <sub>D</sub>			-11.6	dBm	
LOS Assert	LOS <sub>A</sub>	-24		-13.6	dBm	
LOS Hysteresis			1.5		dB	

**Notes:**

- Transmitter consists of 4 lasers operating at 25.78Gb/s each.

2. Minimum value is informative.
3. Hit ratio  $5 \times 10^{-5}$ .
4. Receiver consists of 4 photodetectors operating at 25.78Gb/s each.
5. Minimum value is informative, equals min TxOMA with infinite ER and max channel insertion loss.
6. SRS is measured with vertical eye closure penalty of 1.8 dB max, J2 of 0.30 UI, and J9 of 0.47 UI.
7. Power value and power accuracy are with all channels on.

## V. General Specifications

Parameter	Symbol	Min	Typ	Max	Units	Ref.
Bit Rate (all wavelengths combined)	BR			103.1	Gb/s	1
Bit Error Ratio @ 25.78Gb/s	BER			$10^{-12}$		2
<b>Maximum Supported Distances</b>						
Fiber Type						
SMF per G.652	Lmax			10	km	

### Notes:

1. Supports 100GBASE-LR4 per IEEE 802.3ba.
2. Tested with a  $2^{31} - 1$  PRBS.

## VI. Environmental Specifications

II-VI FTLC1156RDPL QSFP28 transceivers have an operating case temperature range of 0°C to +70°C.

Parameter	Symbol	Min	Typ	Max	Units	Ref.
Case Operating Temperature	T <sub>op</sub>	0		+70	°C	
Storage Temperature	T <sub>sto</sub>	-40		+85	°C	

## VII. Regulatory Compliance

II-VI FTLC1156RDPL QSFP28 transceivers are Class 1 Laser Products. They are certified per the following standards:

Feature	Agency	Standard
Laser Eye Safety	FDA/CDRH	CDRH 21 CFR 1040 and Laser Notice 50
	CSA	IEC60825-2:2004+A1+A2
	TüV	EN60825-1:2014 & EN60825-2:2006+A1+A2
Electrical Safety	CSA	IEC60950-1:2005+A1+A2
	TüV	EN60950-1:2006+A11+A1+A12+A2
	UL/CSA	CLASS 3862.13 & CLASS 3862.93

Copies of the referenced certificates are available at II-VI Corporation upon request.

CAUTION: Use of controls or adjustments or performance of procedures other than those specified herein may result in hazardous radiation exposure.

## VIII. Digital Diagnostics Functions

FTLC1156RDPL QSFP28 transceivers support the I2C-based diagnostics interface specified by the SFF Committee<sup>1</sup>. See also II-VI Application Notes AN-2152<sup>4</sup> and AN-2153<sup>5</sup>.

**IX. Memory Contents**

Per SFF-8665 Specification<sup>1</sup>. See II-VI Application Note AN-2152<sup>4</sup>. For CFP replacement applications, the transceiver module can be customized to enable Tx\_Disable and Rx\_LOS functions as alternate functions on LPMode and IntL pins. See II-VI Application Note AN-2174<sup>8</sup> for more details.

**XI. Mechanical Specifications**

Finisar FTLC1156RDPL transceivers are compatible with the QSFP28 Specification for pluggable form factor modules.

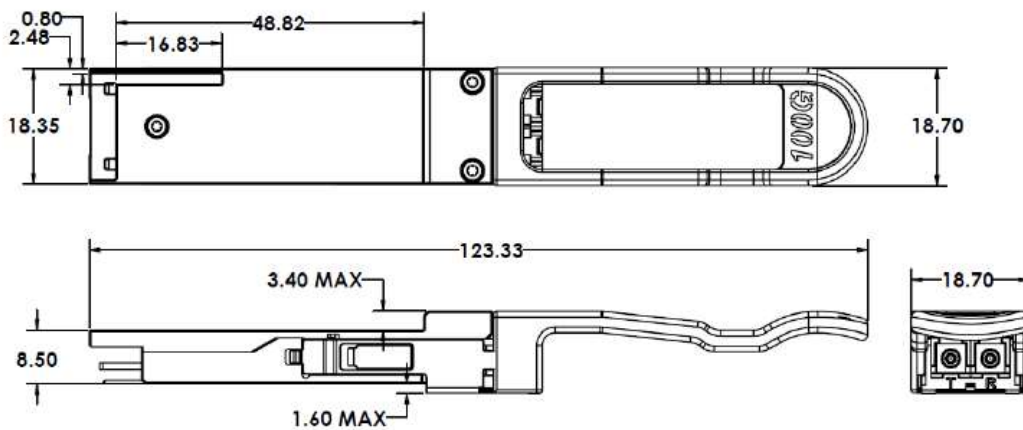

**Figure 2. FTLC1156RDPL Mechanical Dimensions**

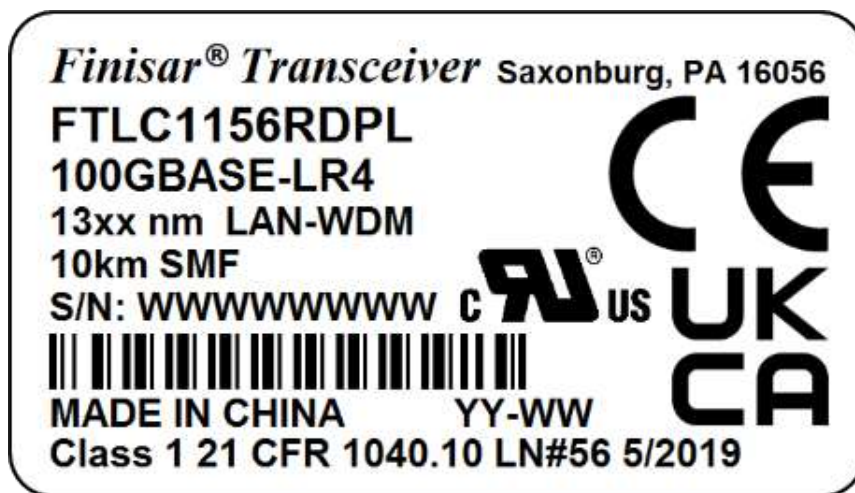

**Figure 3. Product Label (Not to Scale)**

## **XII. References**

1. SFF-8665: “QSFP+ 28Gb/s 4X Pluggable Transceiver Solution (QSFP28)”, Rev 1.9, June 29, 2015 and associated SFF documents referenced therein:
  - i. SFF-8661
  - ii. SFF-8679
  - iii. SFF-8636
  - iv. SFF-8662
  - v. SFF-8663
  - vi. SFF-8672
  - vii. SFF-8683
2. IEEE 802.3ba, PMD Type 100GBASE-LR4.
3. IEEE 802.3bm, Annex 83E, CAUI-4 Interface.
4. Application Note AN-2152: EEPROM Map, II-VI Corporation.
5. Application Note AN-2153: Initialization, II-VI Corporation.
6. Directive 2011/65/EU of the European Council Parliament and of the Council, “on the restriction of the use of certain hazardous substances in electrical and electronic equipment” as well as Commission Delegated Directive (EU) 2015/863 amending Annex II to Directive 2011/65/EU. Certain products may use one or more exemptions as allowed by the Directive.
7. Application Note AN-2038: “II-VI Implementation of RoHS Compliant Transceivers”.
8. Application Note AN-2174: QSFP28 LR4 and QSFP28 CWDM4 Dual Purpose Pins Configuration, II-VI Corporation.

## **XII For More Information**

II-VI Incorporated  
375 Saxonburg Boulevard  
Saxonburg, PA 16056  
[photonics.sales@ii-vi.com](mailto:photonics.sales@ii-vi.com)  
[www.ii-vi.com](http://www.ii-vi.com)